

Kazakov Jury Nikolaevich, Dr.Sci.Tech., the professor, the assistant to the rector of the St.-Petersburg State Architectural Building University, the Chief of the center of tests of building materials, products and designs, the Scientific secretary of SPb of Regional branch, the counselor of the Russian Academy of Architecture and building sciences.

190005, Russia , Saint-Petersburg ,

2-nd Krasnoarmeiskaja str 4 , of 213 St Petersburg State Architectural and Civil Engineering University.

Ph./f. +7 812-316-43-13, www.spbgasu.ru, Kazakov@spbgasu.ru

ENERGY EFFICIENT BULDINGS IN RUSSIA

(work - the winner of VII annual competition PAASN for 2004, Moscow)

Abstract. Urgency of a theme of complex research and design-industrial work on a theme: « Little floors town-planning complexes with energy protect building systems (experience of Saint Petersburg in 1999-2003) » low cost and labour input of works is caused by necessity of development new energy protect building systems for little floors town-planning complexes, and also maintenance of the population with habitation, research of new technologies little floors constructions in country zones where determinatives are the reduced terms of erection of buildings. Progressive technologies of housing construction with use of multilayered designs are in 2004 one of the most important directions of increase of efficiency of a cycle in building sphere of Russia.

History of university

St. Petersburg State University of Architecture and Civil Engineering (SPSUACE) is the oldest Civil Engineering higher educational establishment in Russia. Its history goes back to 1832 when it was founded as Civil Engineering School on the Emperor Nikolas I edict. During more than 170 year University history it was renamed several times:

- Building School (1842)
 - Civil Engineering Institute (1882)
 - Leningrad Institute of Municipal Building (1930)
 - Leningrad Civil Engineering Institute (1941)
 - St. Petersburg Civil Engineering Institute (1992)
- The University bares its present name since June 21st 1993

St. Petersburg State University of Architecture and Civil Engineering (SPSUACE) is the oldest Civil Engineering higher educational establishment in Russia.

Main fields of activity:

- Training specialists at BEng and MEng levels as well as graduated engineers and architects, scientific and teaching personnel (PhD and DSc levels)
- Their continuing education and professional development. Fundamental and applied scientific research
- Spreading knowledge in science and engineering, environment, economics and other fields.

The University offers courses of studies at 4 full-time Institutes as well as at the evening and correspondence departments and the faculty of advanced training. It possesses an extensive portfolio of postgraduate and research degree (PhD and DSc) programmes, Its staff and resources provide support for the Advanced Training Centre for Automobile Transport and Highway System Specialists, Project Management Training and Consulting Centre, as well as for a driving school, preparatory department for Russian and foreign applicants, Russian and foreign languages courses. The academic personnel at 48 SPSUACE departments include 570 lecturers and instructors, among them 5 correspondent members of the Russian Academy of Architecture and Civil Engineering Science, 42 acting and correspondent members of other academies of sciences, 86 DSc, professors, and 338 Candidates of sciences (PhD), assistant professors. Administration and auxiliary staff

consist of more than 1000 people and ensure the necessary teaching levels. The student body totals 6000 students.

The University provides the work of the following centres:

- Certification Test Centre for Building Materials
- Social Engineering Scientific, Training and Consulting Centre
- Commercial Education Centre
- Designing workshop
- International Linguistic Centre
- Scientific and Industrial Consulting Centre of geotechnology.
- Project Management Consulting Centre
- Traffic Safety and Technical Expert Examination Centre
- Advanced Training Centre for Transport Enterprises Executives
- Centre of Modern Construction know-how
- Training and Consulting Centre of Computerized Architecture and Construction Design
- Regional Project Examination Centre of major Repairs and "Reconstruction of buildings and professional education institutions
- Centre of Collective Using

Design of a building

Heatisolation the major value for saving, basically for two reasons has designs.

1. The need(requirement) for heating badly hermetically sealed old building can exceed in 10 times and more similar expenses for the modern ("passive" buildings erected with application saving of technologies. Even standard actions for modernization of a building usually result in decrease(reduction) of losses of heat in 2-4 times, i.e. after modernization of loss of heat make only 25-50 % from a primary level.

2. Constructive elements of a building have enough the big service life. If actions for their repair are not accompanied appropriate ресурсосберегающими by actions, opportunities on improvement of a situation will be lost on opinion of decade forward. At realization of modernization of buildings always it is necessary to provide measures on increase of efficiency saving. In case of acceptance of such decision it is necessary to increase thickness of a blanket as expenses for additional centimeters are usually low.

Structural elements

Walls. In most cases walls play the biggest role in creation of a constructive environment of a building. And in the attitude(relation) saving in a building of a wall are of great importance, as on them it is necessary about 30 % from the general(common) losses of heat.

External warming of walls is the best decision sight of improvement of a physical condition of a building and effective saving. The layer of a heater not less than in 12 centimeters is recommended. In figure 1 two examples of possible(probable) decisions are given.

Windows

For last years there was a substantial increase of quality остекления and windows. It has resulted in essential increase of a level of comfort and decrease(reduction) of losses of heat. According to modern standards it is accepted double остекление windows with special heatisolation a covering, and also filling of space between glasses rarefied gas. Both and another considerably raises that heatisolation windows.

New windows have the greater air impermeability. Thus, a problem of drafts

It is reduced to a minimum, comfort of residing raises and losses of heat are reduced.

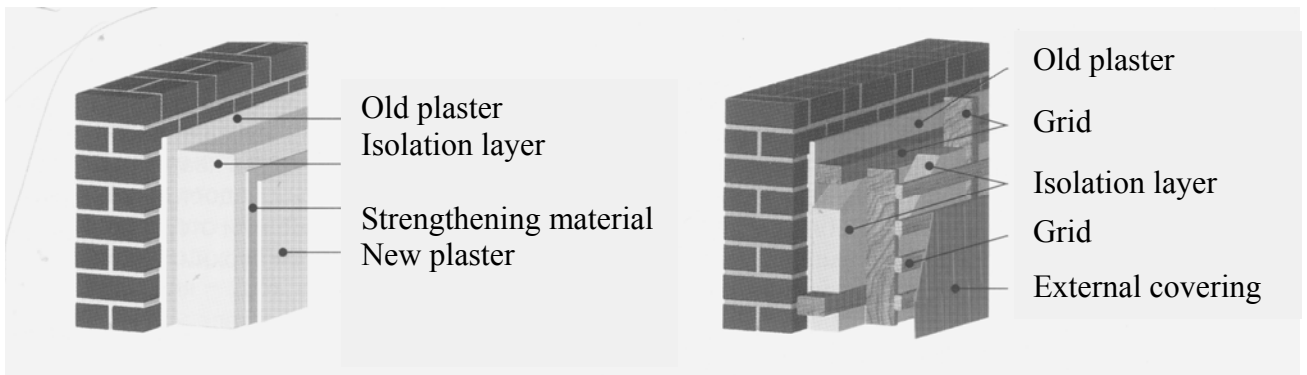

Fig. 1. External Heatisolation walls: warming with drawing new plaster (at the left) and "curtain" (on the right)

However now inhabitants of houses need to pay more attention to necessity periodically to open windows for airing premises(rooms).

Roof/ Ceiling overlappings(blockings) of the top floor

Heatisolation roofs it is necessary in case of presence of warmed premises on the top floor. At absence of such premises the best decision will be heatisolation overlappings(blockings) of the top floor. In both cases it is possible to recommend a layer thickness not less than 20 centimeters. In figure 2 the circuit heatisolation a sloping roof between rafters (at the left) and above rafters (on the right) is shown. Special circuits are applied to flat roofs.

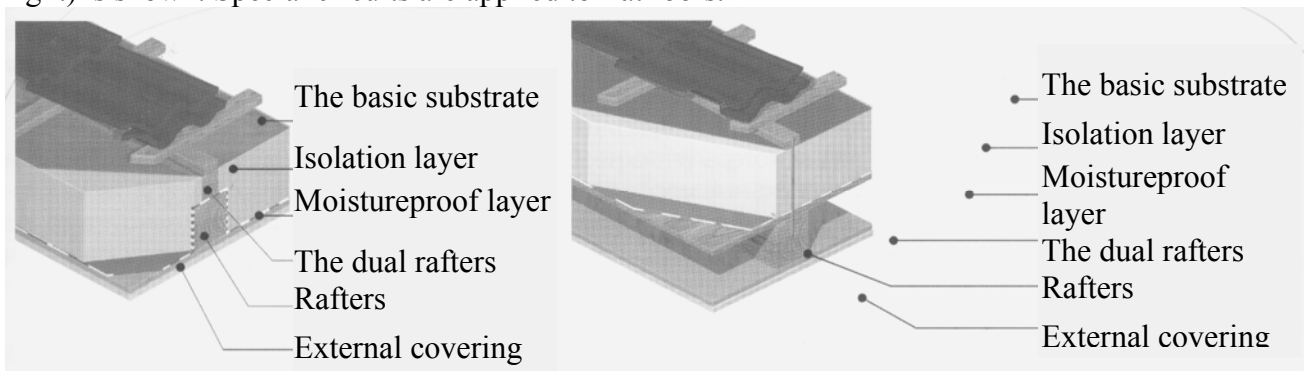

Fig. 2. Heatisolation sloping roof

Ventilation

The certain level of air exchange is necessary both for comfort of tenants, and for procrastination of surplus of a moisture which is always formed during ability to live - as a result of presence of plants, usings a bath. Tenants should watch(keep up) ventilation, and at (airing it is necessary to avoid excessive losses of heat. It is necessary to avoid occurrence of uncontrollable streams of air because of presence of cracks in walls of a building. These cracks also can become the bridge of a congestion of a moisture that will result in the even greater damage of a building. "Environment" of a building should be air-tight, and air exchange - to be carried out on the stipulated channels.

Ventilation usually tenants is carried out by periodic opening windows. If necessary, tenants it is necessary to inform that in case windows are slightly opened all time, air exchange is increased and there is a significant loss of heat. On the other hand, probably, it is required to explain, that the minimal air exchange is necessary for maintenance of quality of air in premises(rooms) and maintenance of safety of a building. Such information will be especially useful at installation of the

new windows providing economy of heat and eliminating drafts. However such windows should be opened much more often, than old as they differ smaller air permeability.

For maintenance of a normal level of air exchange the system of mechanical ventilation is recommended. The best are the systems providing economy of resources due to recycling of heat from exhaust ventilation. However any systems of ventilation demand presence of an air-tight environment of a building which condition is supervised with the help of the test.

Power balance

Already for a design stage not обходимо to calculate needs(requirements) for heating premises(rooms) with applied the appropriate algorithms of calculation, which take into account losses at a heat transfer for all elements of a building (switching if it is possible, temperature planked footway), losses at ventilation. Besides also it can be considered, though it and is less important, the additional heat introduced by tenants, work of electrodevices and solar illumination through windows. The need(requirement) for power resources for heating premises(rooms) makes a basis of calculations of the general(common) need(requirement) for resources which should be fixed in the power passport.

Small installations on manufacture of an electricity and heat can work *in* cellars of apartment houses or the small enterprises. There are models with capacity about 5 kw for manufacture of an electricity and about 10 kw for manufacture of heat.

In pump installations it can be used warmly an environment (usually external air or ground). In local distributive networks pumps with the gas motor though they and have no a wide circulation can be used. Electropumps are usually used. However if such pumps allow to save resources and do not demand the significant investments, much depends on efficiency of pumps in boiler-houses, a production efficiency of the electric power in municipal objects and networks, and also from cost of the electric power. The ecological effect can be received due to use of a solar energy. Warmly it is generated in the solar batteries, however the full system usually includes also the store. Small installations can provide only hot water, presence in a building of system of the central hot water supply therefore is necessary. The contribution of solar batteries makes about 50 %. Larger installations can provide also 10-20 % of need(requirement) for heating. Economic conditions of installation of solar batteries usually it is better in the big buildings, however the full covering of charges is practically impossible without special grants.

Recommended actions on modernizations and to repair of buildings in Russia

Technical actions on saving in housing sector can be divided(shared) into three groups conditionally:

- 1) Actions for the account of quantity(amount) and quality of consumed resources;
- 2) Actions for regulation of consumed resources;
- 3) Actions for decrease(reduction) of irrational losses of consumed resources.

Actions for the account of quantity(amount) and quality of consumed resources

Devices of the account allow to supervise consumption of resources and to carry out payment not for normative, and for their actual use. It in itself serves as good stimulus for decrease(reduction) of irrational losses.

It is necessary to notice, that the account of consumption of resources as a whole is possible(probable) at two levels - measurement of consumption as a whole on a building and consumption in separate apartments. In the future we anyhow shall come to necessity to measure consumption of resources in apartments, but already now in some cases it is expedient to begin with the account of consumption at a level of a building.

The account of resources in a building allows to pay their delivery for the fact of consumption, at the same time an establishment of a share of each consumer in a building in payment of resources probably only at measurement of consumption in each separate apartment.

Thus, for buildings as a whole the most important action is installation of units of the account of thermal energy and water, to less paid back measures concern installation registrars of heat and counters of gas.

For separate apartments quickly paid back action is installation of counters of hot and cold water, on the second place there is an installation of two-tariff electric meters.

Installation of units of the account of thermal energy and water

Units of the account of thermal energy and water are established or on input in a building of pipelines of system regional is warm also water supply, or in structure of individual thermal items(points).

Basic element of unit of the account of thermal energy is registrars which structure includes flowmeters, thermocouples and the gauges of pressure established(installed) on direct and return pipelines of system of heating, and also the calculator. A basic element of unit of the account of water is the flowmeter.

The most widespread are ultrasonic, induction and mechanical flowmeters. The calculator carries out functions of registration and storage of the information on the charge, temperature and pressure of the heat-carrier. In the table given here the parity(ratio) of actual and normative consumption of thermal energy and water for 92 buildings located in cities (the data for the heating period of 2002/03) is shown. Measurements were carried out(spent) before realization actions.

Table 1

Parity(ratio) of actual and normative consumption thermal Energy and water

City	The attitude(relation) of actual consumption of resources to normative, %		
	Heating	Hot water supply	Cold water supply
Cherepovets	114,4	162,3	96,5
Orenburg	97,6	98,6	99,2
Ryazan	84,6	96,1 1	72,3
Vladimir	99,3	07,7	90,5
Volkhov	95,1	84,8	-
Petrozavodsk	81,8	120,9	106,8

Installation of units of the account of cold water

The account of cold water is expedient for carrying out(spending) both for all building as a whole, and for his(its) separate apartments. The structure of unit of the account established(installed) on input in a building of the pipeline of system of regional water supply, includes a flowmeter, the gauge of pressure, the filter, narrowing devices and запорная armature. In addition to unit of the account the pipeline (байпас), supplied запорной is mounted by armature which opens at occurrence in a building of a fire and other emergencies bypass. The flat account of cold water is conducted the same as also hot water.

Installation of units of the account of gas

The account of gas is expedient for carrying out(spending) for all building as a whole or several it(him) parts, but not for separate apartments. The structure of unit of the account established(installed) outside of a building on the pipeline of system of regional gas supply or on his(its) tap(removal) inside an entrance, includes a flowmeter, the filter and armature. At an external arrangement of unit of the account important that his(its) design excluded freeze rotating parts of a flowmeter in frosty time.

In figure 25 results of measurements of consumption of natural gas in multiroom buildings of Orenburg are submitted. Mid-annual consumption has made only 64 % from the specification.

Installation of electric meters

As a rule, all buildings and their apartments are already provided with electric meters. Replacement of old counters by the new models providing the big accuracy of measurement of parameters of the electric power is expedient and allowing with the purpose of use the tariff separately to fix consumption in day time and night time.

Actions for regulation of consumption of resources

Regulation of consumption of resources is, as a matter of fact, process of restriction of their superfluous offer. Therefore effective regulation is possible only at presence at the municipal organizations of sufficient capacities on manufacture of resources and at maintenance of the design parameters of delivered resources stipulated by contracts with them.

As initial configurations of engineering systems of a building are various, also their modernization is made by various ways. However all works, as a rule, are interconnected also their realization should occur on a general plan.

Actions for decrease(reduction) of irrational losses of consumed resources

Performance of actions for the account and regulation allows to provide normative conditions of residing and precisely to define(determine) the quantity(amount) of resources consumed for it and their cost, creating thus conditions for the analysis of irrational losses and acceptance of decisions on their decrease(reduction).

The examples submitted further do not settle(exhaust) all ways of decrease(reduction) of irrational losses of consumed resources.

External warming wall designs and arch apertures

External warming wall designs allows to provide more comfortable conditions of residing in apartments at essential decrease(reduction) of thermal losses.

The layer of isolation is established with the help речных directing, attached to walls by bolts. Outside to it(him) it is attached additional a layer, and on him(it) - a blanket with the raised(increased) density. Then the covering which is carried out, for example, from the corrugated zined metal sheets with a plastic covering is established. Between a blanket and a covering the vertical air backlash should be stipulated.

This design named « a ventilated facade », provides maintenance of positive temperature of bearing(carrying) walls and gradual reduction of their humidity, isolates available « planked footway of a cold » and in a result approximately in 3~4 times reduces thermal losses through wall designs and essentially prolongs term of their service.

Warming of arch apertures results in increase of temperature of air in adjoining apartments на4-6°C.

Restoration of closing up of interpanel seams and waterproof walls

Restoration of closing up of interpanel seams and waterproof walls is be relative actions for decrease(reduction) of thermal losses in panel buildings.

Service life of interpanel seams usually essentially is less, than service life of panels. Restoration of closing up consists from some operations: removals(distances)

Old closing up; repair of edges and reduction of the sizes of seams in the size more than 25 mm a solution; stacking of a new tape lining from polythene with the closed cells, covered with polythene; drawings first coats on cement surfaces of seams; stacking of new closing up and painting of seams.

Waterproof represents drawing on preliminary prepared external surface of panels of the special solution giving to it(her) waterprotect property interfering formation(education) on it(her) of organic connections and keeping her(it) air permeability.

Warming of building designs of attics, technical floors and cellars

Warming of building designs of attics, technical floors and cellars will allow to cut expenses on heating of uninhabited premises(rooms) of a building at maintenance of normative conditions in apartments adjoining to them.

Isolation of attics is carried out from sprayed mineral cotton wool or glass wool with the minimal shrinkable characteristics or from the plates made of the same materials. Thickness of a layer of isolation should make from 10 up to 20 see.

At isolation of a ceiling of cellars frequently use plates from mineral cotton wool or glass wool thickness not less than 5 sm which become covered by a layer of the aluminium serving for protection against a moisture and mechanical damages.

Isolation of pipelines of heating and hot water supply

Isolation of the pipelines which are taking place in uninhabited premises(rooms), allows to lower irrational losses in system of heating and hot water supply.

At isolation usually use synthetic rubber, used on heating installations, or trumpet section from the formed mineral cotton wool, covered with an aluminium foil which is reinforced with fiber glass.

Table 2

Parity(ratio) of actual and normative consumption thermal Energy and water

City	Expenses economic, dollars. USA	Specific expenses, dollars. USA on m ² of the general(common) area of buildings	Share of expenses for modernization ИТП and installation of unit of the account, %	Economic internal norm of profitableness, EIRR, %	Time of recovery of outlay economic, years
Cherepovets	627576	6,8	57,3	34,0	3
Orenburg	1040893	11,3	28,5	11,3	8
Ryazan	1231725	9,1	29,9	54,7	2
Vladimir	758182	7,9	45,9	21,8	5
Volkhov	292303	22,0	43,7	13,8	7
Petrozavodsk	656204	10,5	45,0	10,2	9

The Practice of use of collapsible buildings of system "Module" in usual conditions in settlements in the Far North

Experimental researches of collapsible buildings of system "Module" were carried out in the Far North in Norilsk area.

Overall objective of work was introduction and check in practice of scientific and technical bases of creation of new collapsible buildings of system of perspective generation "Module" and the forecast of the further development of military systems for accelerated accommodation of the building organizations.

Objects of research were hostels, kitchens - dining rooms, educational classes and other buildings making up camp settlements of builders.

The basic adverse factors and their reflection in constructive and planning decisions of military buildings in view of suggestions of the VITU are shown in fig. 3.

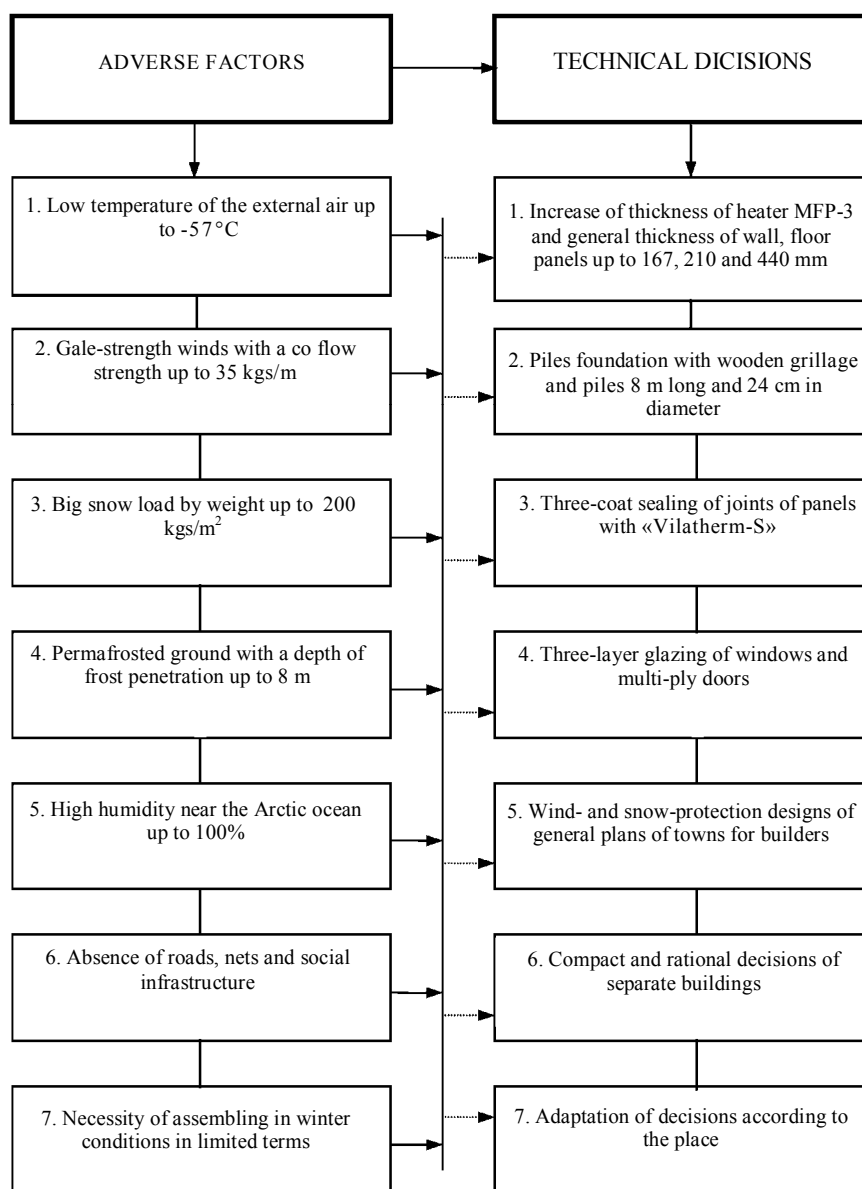

Fig. 3. Structure of the basic non-conventional factors and their technical decisions during experimental researches in the Far North

As may be seen from the data submitted in fig. 4.2 during creation of the adequate environment able to resist to adverse natural-climatic factors in complexes there were used the following technical decisions:

Firstly, external walls have the increased thickness of 167 mm (instead of 113 mm for usual conditions) due to increase of thickness of new perspective heater МФП-3 – urea-formaldehyde filling foam plastic on a basis of urea pitches along metal-wood frame with coverings made with waterproof broadside plywood.

Secondly, for warming of floor panels the additional heater insulation is used - a layer of mineral wool hoards at a level of wooden grillage of the base with the general thickness of floor panels of 440 mm.

Thirdly, for protection of internal space against the wind and cold air there are applied three-layer sealing interlining tapes of a new special porous sealant "Vilatherm-C" instead of the typical two-

layer decision.

Fourthly, plywood such as FSF by thickness of 19 mm for a floor, coverings and walls and by 12 mm for partitions is accepted as the basic material for coverings of panels.

Fifthly, it is used a new heater which differs by low heat conductivity ($\lambda = 0,03 \text{ Wt/m} \cdot ^\circ\text{C}$), by small density 23 kg/m^3 at humidity of 15 %, does not burn, resistant to vibration, does not freeze and possess sound absorbing qualities. Besides as have shown tests, in expanded composite the contents of a liquid is reduced by 40-60 % in comparison with usual heaters due to that during filling a frame of panels by 160 DSK the drainage of a liquid is practically excluded, adhesion of foam plastic to coverings increases and shrinkage is reduced.

Sixthly, the pile wooden base with piles of length of 8 m, diameter 24 cm and grillage made with timber of section 25 x 25 cm is applied.

Seventhly, space -planning and town-planning decisions in general plans of small towns and of separate buildings for the decision of the wind-and snow-protecting measures are used.

Due to necessity of urgent maintenance of basing of camp settlements the works were conducted in the winter time, in two - three shifts in any weather conditions, during polar night, snowfalls and strong frosts. Installation was carried out by means of truck crane KS-356 2A by carrying capacity 10 t. For drilling of wells for piles a drilling-crane machine BM-802S on base of KрA3-257B was used. The building site for foundation was provided with a mound of medium-grained sand with an average thickness of a layer of 2 m. Weight of the heaviest assembled element of system " Module " (panels of overlapping in the sizes according to the plan of 4,8 x 2,4 m) was 516,6 kg.

Results of experimental construction

Distance of transportation of complete sets of buildings from N 160 DSC (building plant) in the town of Korolev of the Moscow region up to Norilsk makes 4100 km. Installation was carried out in three working shifts under any weather conditions. The temperature during experiment changed from -48°C up to -14°C, humidity from 90 up to 100 %, there was a strong snow constantly, speed of a wind reached 40 m / s. In conditions of a polar night the platform was constantly lighted by floodlights.

Installation was carried out by a brigade in a quantity of 7 persons: one operator of the truck crane of 5-th class, two slingers and four assemblers of 4-th class. The master having special secondary education supervised the installation.

Duration of installation of buildings in small towns has made from 20 up to 45 days.

To the revealed advantages it is possible to attribute the fact that all buildings were installed without further alteration in a place of constructive elements. At an icing of connected surfaces ice was chopped off by an axe with the subsequent cleanup of the metal. At speed of a wind more than 20 m/s stability of mounted elements was provided by bounding with a rope attached to the bottom tenons or mortises of constructions.

Second, as mainstreams of the further development of the system "Module" were determined certain contradictions allowing to raise the technological level of the system as a result of their rational resolution. To them it is possible to attribute the following prospective directions:

- Increase of rates of installation of the piles foundation and a roof by means of development and application of collapsible unified lightweight designs of the northern, southern and usual variants;
- Development and use of new weatherproof sealers for hermetic sealing of joints in external protecting constructions for the Far North conditions;
- Development of non-conventional, alternative approaches to designing of QC on the basis of collapsible buildings with the use of principles of adaptability to concrete needs of users;
- Realization of reserves of transformability of systems in the process of exploitation by consumers

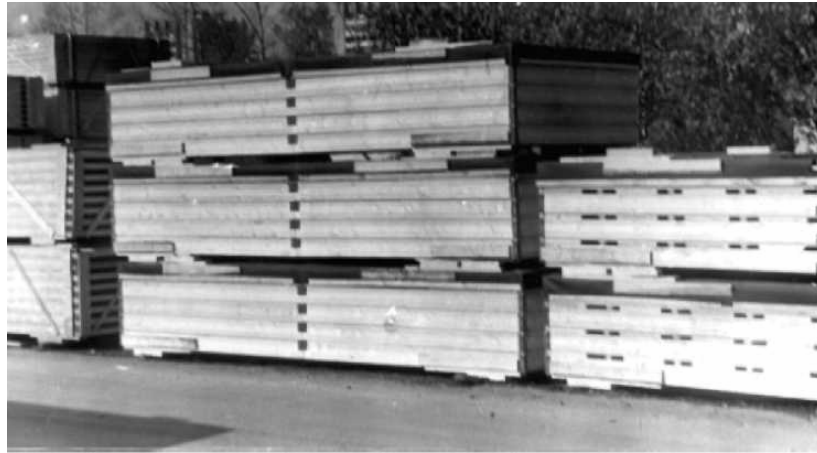

Fig. 4. Transport packages of flat and linear constructive elements of a collapsible hostel of the system "Module" for Far North conditions



Fig. 5. Installation of quickly erected hostels for 60 persons with the pile wooden foundation and grillage in conditions of permafrost of the ground in the Far North



Fig. 6. Quickly erected kitchen - dining room assembled in conditions of the Far North at temperature up to -48°C and speed of a wind up to 40 m/s without attraction of the building organizations

without attraction of design and operational organizations and representatives of enterprises - manufacturers;

-Increase of thickness of heaters and exception of through -heat-transmission inclusions in a zone of joints of metal tenons and stake pockets and overlapping by interruption of such joints in the middle part with inclusion of thermal isolation disks or linings;

-Designing of complex buildings for the Far North instead of separately standing buildings;

- Replacement of a flat roof by pitched one for prevention of formation of rain and snow lenses and bags;

- Replacement of the wooden steps breaking during the first year of operation by metal ones;

A technique and results of the use of
Domestic and foreign container complexes
At liquidation of consequences of earthquake

Work was carried out in military stations and civil settlements of the cities Spitak, Kirovakan, Leninakan, Yerevan and other settlements of Armenia. During its realization a large-scale natural experimental researches of domestic systems " Sokols ", "Module", "CUM", "SRM" (tab. 1.3, fig. 1.2), and also representing special interest new for the Russian Federation transforming buildings "Portakabin" и "ITALSTAK" produced by USA, the Great Britain and Italy were carried out.

Objects of research were 826 buildings of hostels, staffs, dining rooms, clubs, warehouses and special objects, and also dwelling houses, hospitals, first-aid posts, combines of consumer services, points of communication, administrative objects, hospitals, and also small towns for domestic builders, dwelling complexes of rescuers from Norway, France, USA, Italy and the Great Britain.

As have shown researches, extreme character of the erection of QC in Armenia was determined by the following major factors: twenty-four hour basis of conducting of regenerative works, integrated approach and scale of installation of hundreds of mobile buildings simultaneously, the poorly developed local infrastructure and, especially, a transport network, a difficult mountain relief of the land, absence of the local advanced base for the building industry, the destroyed sources of engineering maintenance of the processes of installation of QC.

The general view of the camp settlement of builders from tents and containers is given in fig. 7.

The Process of installation of two-storey dwelling houses of the system "Module" is submitted in fig. 8.

The analysis of a condition of manufacture of effective materials has shown high efficiency of cellular concrete. However, their manufacturing is carried out exclusively industrially as a principal cause is the requirement of normative documents on temperature of air not below 15°C. The given circumstance is caused by features of formation of structure of cellular concrete and limits area of his use, not allowing to carry out manufacture in conditions of building sites. In this connection application of cellular concrete in mass housing construction restrains it enough in high cost of manufacturing industrially. Therefore there is a problem of development of more perfect technology малоэтажного housing construction with application of designs from a nonconventional material – porous concrete (TPB). The purpose of work is development new energy protect building systems for little floors housing construction with application of designs from porous and the termo-vacuum concrete, providing increase of heat-shielding properties of external protecting designs, walls and overlappings and depreciation of construction.



fig. 7. A general view of the camp settlement of builders in the village Pushkino made with tents and containers for the building organizations which have taken part in liquidation of consequences of earthquake in Armenia



Fig. 8. Installation of two-storey apartment houses of the system "Module" near the city Stepanavan by the builders of the state cooperative enterprise "Lenooblagrostroy" (Stepanovan specialized building administration)

For achievement of the purpose put during research by a group of authors the following problems are solved:

- The technology of preparation and stacking monolithic porous a concrete mix in building conditions little floors housing construction is proved;
- The technology of application of elements of a fixed timbering for erection of monolithic designs from porous concrete mixes is developed;
- Theoretical researches of technical and economic efficiency of application porous concrete in designs of walls and overlappings are lead;
- Introduction and check of efficiency of technological decisions in conditions of building sites are carried out at erection little floors town-planning complexes.

As object of research act little floors town-planning complexes at all stages of a work cycle of their erection. Object of research is the technology little floors housing construction with use new energy protect building systems - designs from porous (aerated) concrete prepared in conditions of a building site. Technique of researches: the system analysis and synthesis; mathematical statistics and the theory of probability; kvalimetry; theoretical and experimental researches in laboratory conditions of processes porous creating and aerations of concrete mixes; a theoretical and experimental substantiation of parameters of perfection of technology of reception and application porous mixes and aerated concrete. Reliability of results of research proves to be true enough of the lead experiments, use of the checked up equipment and standard techniques, a choice of adequate models and methods, application of methods of statistical processing of the information with the help of a computer, sufficient convergence of practical and theoretical results of the research, the constructed town-planning complexes in Saint Petersburg in 2000-2004.

Scientific novelty of research consists in the following:

1. The technology of preparation porous mixes and aerated concrete in conditions of a building site is proved on the basis of cement, sand, sawdust, перлита, waters and foam creator with average density 1150 - 1250 kg / m³ and durability at compression 5 - 8,5 МПа.

2. The technology of application porous monolithic concrete as constructive – warm keeping a material for multilayered designs of external walls and in designs of overlappings in little floors housing construction is developed.

3. The technology of application of elements of a fixed timbering is offered on the basis of the unified obverse and ordinary products from effective concrete by thickness of 40 mm and width of the various length 300 mm, allowing to lower transport and an overhead charge at construction.

4. Rational scopes porous concrete in little floors housing construction are revealed in view of his bearing and protecting functions, durability and warm protecting properties.

5. Technical and economic efficiency of application of designs from porous mixes and the aerated concrete, consisting in depreciation of building materials and budget cost of construction, and also in increase of heat-shielding properties of external protecting designs is proved.

The practical importance of work consists in use of substantive provisions in practice in the construction organizations and in educational process of higher educational institutions of Saint Petersburg. Results of research are finished with an opportunity of their practical realization. On the basis of results of research the production schedules on erection малоэтажных at home from collect-monolithic designs with a fixed timbering are developed. The offered recommendations are introduced on objects of new housing construction into Open Company " MasterBuildCompany " in Saint Petersburg per 1998-2003 (Pushkin, Pavlovsk) where have been erected малоэтажные town-planning complexes from a brick with internal filling porous concrete. Thus, the economy of budget cost of construction on 10 - 15 % has been received in comparison with known comparable designs. The technology of works with porous concrete differs simplicity of performance of operations and the economical charge of building materials. Cost of manufacturing and stacking of concrete makes 350 - 400 rub/m³, that in 1,5 - 2 times are more economic than use of blocks gas concrete factory manufacturing in item. Sertlovo. Results of research are introduced in educational processes SpbGASU on faculty of technology of building manufacture and VITU on faculty of building materials in 1997 - 2005. Porous constructive concrete time the structures, made by a method of aeration, is tested and certificated in the center "Acceptance" (the Certificate of accreditation of test laboratory № GOST P RU. 9001.6.1.0029 Gosstandart of Russia, Minstroy Russia, № 00261 from 7/19/1996 of). Results of four-year-old supervision over a condition of the constructed buildings show, that bearing designs keep the explutation qualities, thus confirming scientific validity and reliability of the developed decisions.

For an estimation of efficiency as basic two variants of traditional technology of erection of external brick walls for little floors apartment houses (tab. 3.) are accepted.

Table 3

System of technical and economic parameters of variants of technology Manufactures of works for the device of external walls of apartment houses

System of Technical and economic parameters	Variants		
	№ 1 continuous brick wall	№ 2 layered brick wall with gas concrete blocks	№ 3 brick wall with aerated concrete
Thickness of a wall, sm	77	58	81
Durability, MPa	10	2	5
Heat conductivity, W/m°K	0,26	0,10	0,25
Volumetric density, kg / m3	1100	400	1150
Cost of 1 m3, rub	1500	820	350
Frost resistance, cycles	25	25	25
USE charges, rub	Are accepted identical		
The sizes, mm	250x120x65	600x300x250	Monolithic variant
Fire resistance	Group of nonflammable building materials in accordance with GOST 30244		
Cost of 1 m2, rub	1171	622	562
Use of waste products of manufacture	No	No	Is

Variant №1 - a continuous brick wall from the effective hollow ceramic brick made according to GOST 530-95 NPO "Ceramics" of of Saint Petersburg.

Variant №2 - a layered brick wall with gascocrete the blocks made 211 KGBI in items. Sertlovo of Saint Petersburg and a brick by a variant №1.

The initial data of variants are resulted in tab. 1. and on fig. 9.

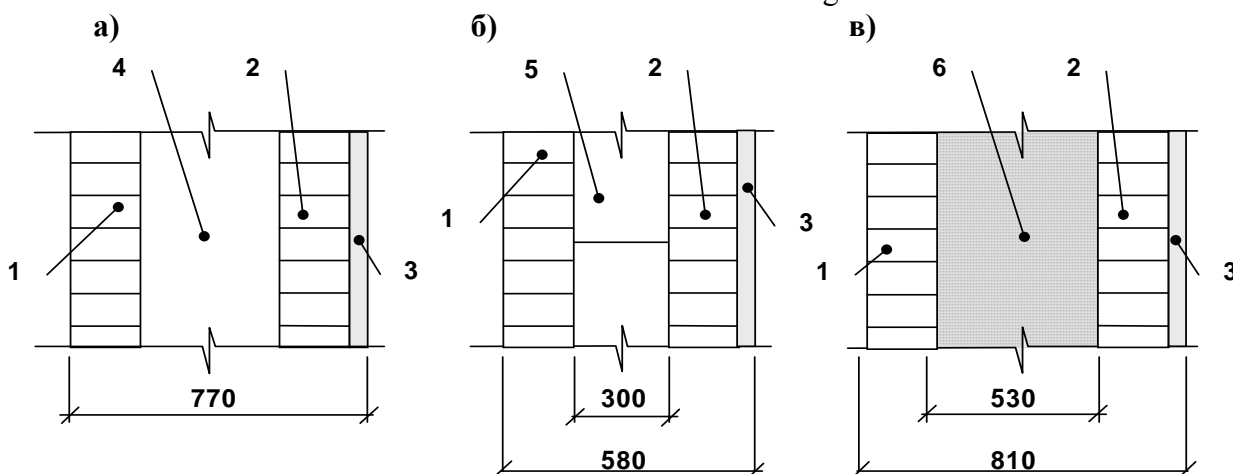

Fig. 9. Compared variants of technologies of the device of brick external walls for little floors apartment houses in conditions of Saint Petersburg: and - a continuous bricklaying (a variant № 1); in - multilayered bricklayings (variants № 2 and № 3);

1 - an external number of a brick; 2 - an internal number of a brick; 3 - plaster; 4 - an average layer of a brick; 5 – gas concrete blocks; 6 - porous-sawdust-sandy monolithic concrete.

Thus, developed (a variant №3) technology ТПБ in 2,1 times is more economic than existing technology of a continuous brick wall and in 1,11 times - technology with gas concrete blocks. The received data are evidently reflected on fig. 10.

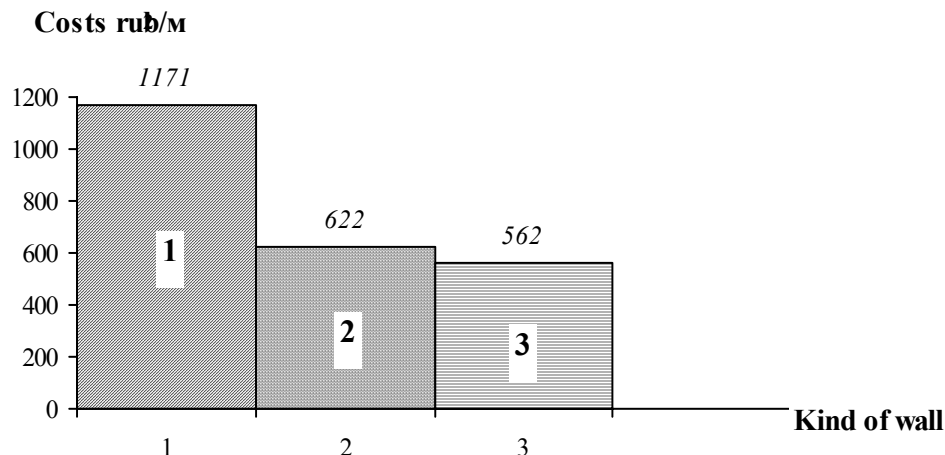

Fig. 10. Comparative values of cost of an external wall of 1 m²

Various constructive decisions:

1 - a layered brick wall from porous brick NPO "Ceramics" (a variant № 1); 2 - a layered brick wall with gas concrete blocks 211 KGBI (a variant № 2); 3 - a layered brick wall with source monolithic sawdust-sandy concrete (a variant № 3).

Thus, it is logical to draw the following conclusions.

1. The technology of application energy care building systems in little floors town-planning systems with use of designs from porous sawdust-and perli concrete is developed. The technique of a technical and economic estimation of efficiency of the offered technology at all stages of a production cycle is proved: factory manufacturing, transportation, performance of civil and erection works, operation of the erected designs.

2. The analysis of variants of use of designs from aerated concrete has shown their high technical and economic efficiency in comparison with comparable modern analogues. In comparison with technology of a continuous brick wall from porous a ceramic brick in density of 1100 kg / m³ heat conductivity 0,26 Вт/м ОК manufactures НПО "Ceramics" (of Saint Petersburg) the effect makes 609 roubles on 1 m² of a surface of an external wall. Expenses for a bricklaying make 1171 roubles / m², and on a concrete laying - 562 roubles / m², i.e. in 2,1 times it is less. In comparison with technology of a bricklaying with use газобетонных blocks in density of 400 kg / m³ heat conductivity 0,10 Вт/м ОК manufactures 211 KGBI (item. Sertlovo) the effect makes 60 roubles / m². Expenses on газобетонную a laying are made with 622 roubles / m², that in 1,11 times is higher than the developed monolithic technology.

3. Research has shown high efficiency and perspectivity of expanded use of the offered technology porous concrete for the construction organizations in Saint Petersburg at erection little floors apartment houses. Rather - economic efficiency of technology at use of one mixing installation at service by one working reaches 1,734 million roubles a year, and two installations with two working - 4,624 million roubles a year.

4. Introduction of the developed technology porous concrete and check of efficiency of technological decisions in conditions of building sites of Saint Petersburg is executed at erection little floors apartment houses. The technology is used by Open Company « the Master Build the Company » at construction of two and three-tier apartment houses in. Pushkin and. Pavlovsk in 1999 - 2003. Experience of use of technology has shown sufficient convergence of theoretical settlement parameters of efficiency

with practical estimations on the facts of construction and operation. Thus the technology of works with porous concrete differs the economic charge of accessible building materials and simplicity of performance. The technology allows a message of work at negative temperature (up to -15 0C) with use against frost additives and a covering бетолируемых surfaces warm keeping mathes.

5. The technology of use porous the concrete, based on preparation of a mix in specially developed optimum concrete mixes is offered to installation and stacking of a mix between an internal and external layer of a multilayered bricklaying in external walls of apartment houses. Offered technological and constructive decisions allow to use optimum constructional (bearing) and heat-shielding (protecting) properties porous concrete on the average a layer of a wall, to reduce quantity of seams and joints and to organize technological process on a building site. It provides achievement of an object in view, deprecation of construction and increase of heat-shielding properties of external protecting designs.

The appendix



a) A panorama of houses from the party



6-room
energy effect the house
Complex of 2 floor buildings

Domestic facades;

Photo 1. A town-planning complex of a housing estate two-storeyed houses with the penthouses erected in SPb in 1999. Pushkin, Pavlovsk highway, д. 61, 63, 65.



a) A domestic facade



б) A multilayered external wall with an internal layer from porous monolithic concrete

Photo 2. Little floors a town-planning complex of 3 floor apartment houses with penthouses in Saint Petersburg. Pavlovsk, street. Vasenco, h. 5. Year of construction - 2001.



a) Absence of operational remarks for 2 years



б) porous monolithic concrete in external walls and overlappings in a mansard floor

Photo 3. little floors a town-planning complex from 3 floor apartment houses with penthouses in Saint Petersburg. Pavlovsk, street. Vasenco, h.5. Year of construction – 2001:

REFERENCES

1. Kazakov J.N. .Perspective's of a direction of development quickly build systems for basing mobile and peace-making forces in zones armed conflicts // the Problem of quality of building production: Report. On May, 27, 1999 (a part II). - SPb., 1999. - With. 19-22. Confidentially № 31103.
2. Kazakov J.N. .Forecast's of development in the future quickly erected military Building complexes MO the Russian Federation and the countries of the NATO // Problems modernGeopolitics. Promotion of the NATO on the East. - Problems of safety of Russia and the countries CIS: Report . 1, 1999-SPb., 1999.-C. 181-186.
3. Kazakov J.N. . Quickly build individual apartment houses // Quickly build and mobile buildings and constructions: prospects of using in modern conditions: Report 10-11 December 1998г.-SPb., 1998.-C. 176-178.
4. Asaul A.N., Kazakov U.N. Theory and practice of use of quickly erected constructions in general conditions and in state of emergency in Russia and abroad. Under edition of Doctor of Technical Sciences, professor Kazakov U.N. – Saint-Petersburg : “Gumanistika” 2003, -412 p.
5. Asaul A.N., Kazakov U.N. Little floors housing construction – Saint-Petersburg : “Gumanistika” 2005, -570 p.