

# Mechanical Ventilation System with Heat Recovery in Arctic Climates

Jesper Kragh

Assistent research professor  
Technical University of Denmark

Energy-efficient building

April 12<sup>th</sup> – 14<sup>th</sup> 2005 · Symposium in Sisimiut





# Agenda

- Ventilation in normal houses
- Ventilation heat loss and energy saving potential
- Heat recovery in cold climate – freezing problem
- The ventilation system in the low-energy house
- Test of the heat recovery unit at DTU
- Other solutions of the freezing problem
- Conclusion



# Why ventilate ?

- Water vapour (10-15 l pr. family pr. Day)
- Scent from people
- Gasses from furniture and building components
- High indoor temperature

## Insufficient ventilation

- Poor indoor climate
- Higher risk of mould and rot in building constructions



# Ventilation demands in the coming building code

Total air change rate:  $0.5 \text{ h}^{-1}$

Extracted air flow demands:

Kitchen 20 l/s

Bathroom 15 l/s

Toilet 10 l/s

Scullery 10 l/s

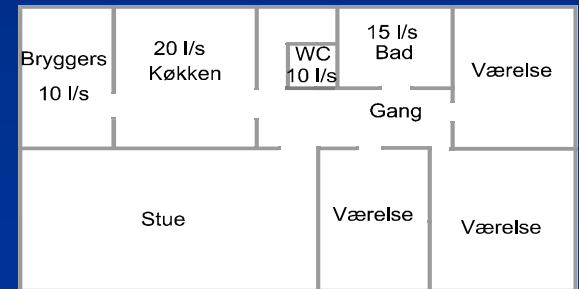

Example: House of  $100 \text{ m}^2$ .

Outside temperature  $-10^\circ\text{C}$  and inside  $+20^\circ\text{C}$ .

Ventilation heat loss:  $1.0 - 1.2 \text{ kW}$

# The heat recovery unit

The energy in the extracted air is used to heat the cold inlet air (from the outside).

The energy saved depends on the heat exchanger's efficiency.

Cross flow heat exchangers	$\eta = 60 - 70 \%$
Rotating heat exchangers	$\eta = 60 - 80 \%$
Counter flow heat exchangers	$\eta = 85 - 95 \%$



# Example of small compact heat recovery unit with ventilators, heat exchanger, filters and control system ( $\eta = 90\%$ )



# Test of small compact standard heat recovery unit

Efficiency of the heat exchanger:  $\eta = 90 \%$

Room temperature:  $21^{\circ}\text{C}$

Relative humidity:  $42 \%$

Outside temperature:  $-5^{\circ}\text{C}$

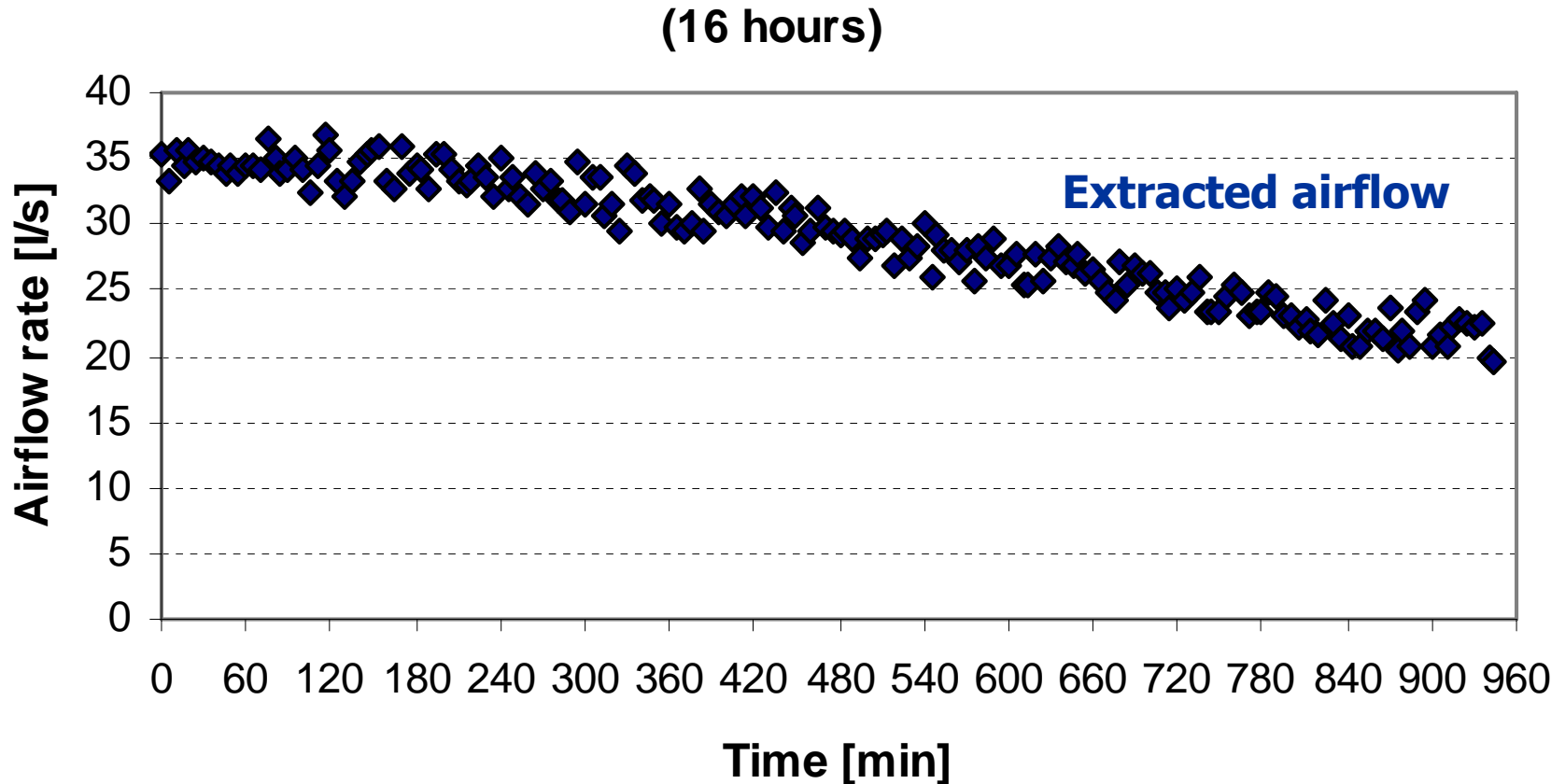

# Preheating the inlet air

## Energy consumption for preheating the inlet air

(House of 100 m<sup>2</sup> with an air change rate of 0.5 h<sup>-1</sup>)

Weatherdata: Sisimiut

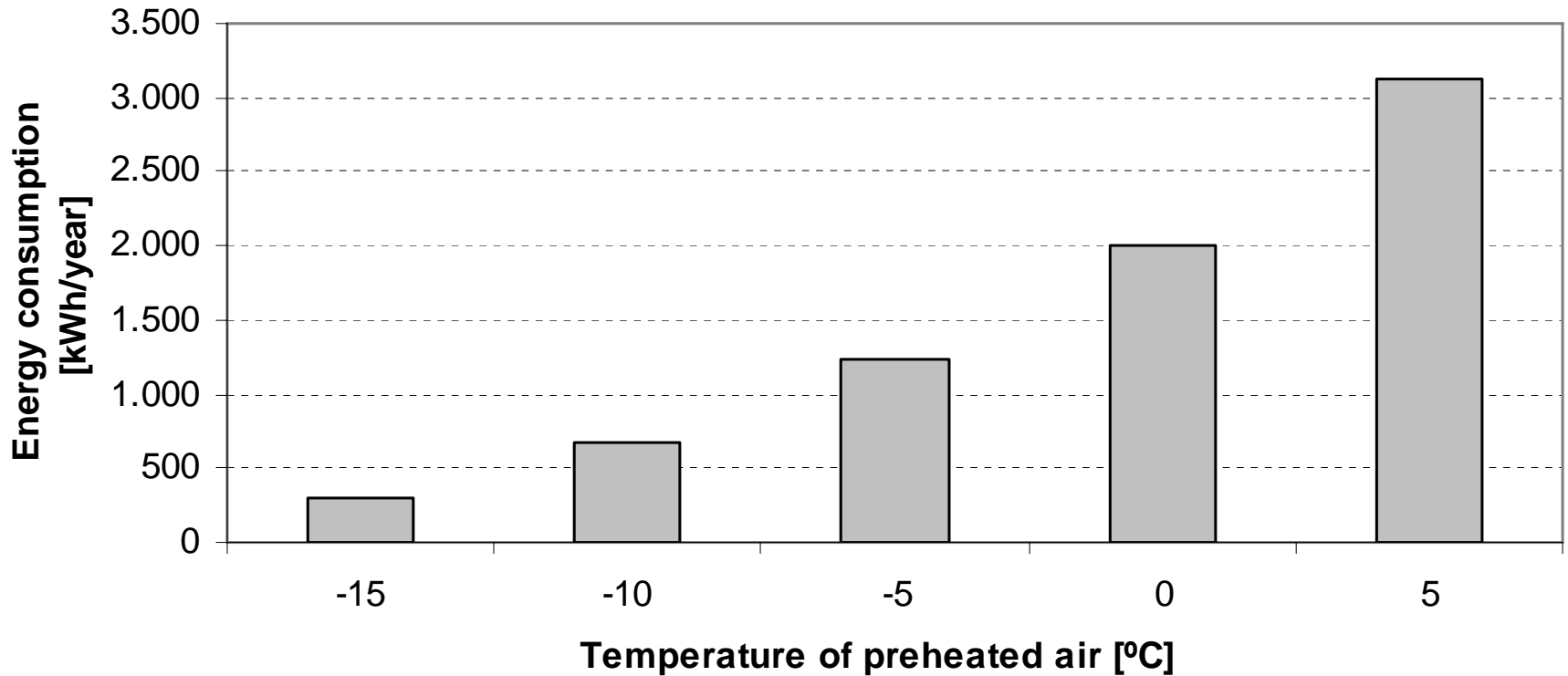

# Annual energy saving potential (100 m<sup>2</sup> house in Sisimiut)

	Ventilation heat loss	Preheating	Fan energy	Savings
	kWh	kWh	kWh	kWh
<b>Ventilation with no heat recovery</b>	9,000	0	0	0
<b>Today's solution: Heat recovery (60%) Preheating (-10°C)</b>	3,300	700	600	4,400
<b>Improved system: Heat recovery (90%) No preheating</b>	900	0	600	7,500

# The ventilation system in the low-energy house

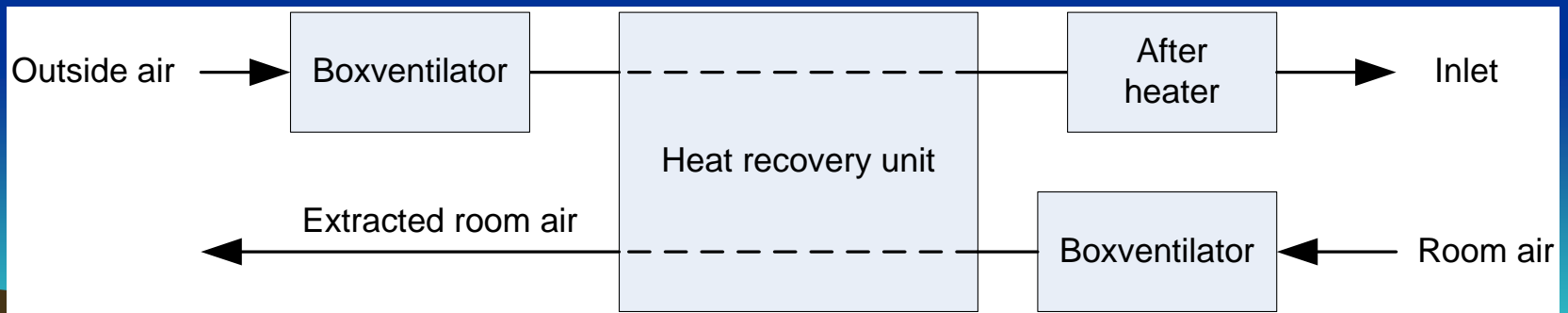

# The ventilation system in the low-energy house

Heat recovery unit developed for the low-energy house in Sisimiut in cooperation between EXHAUSTO A/S and the Technical University of Denmark

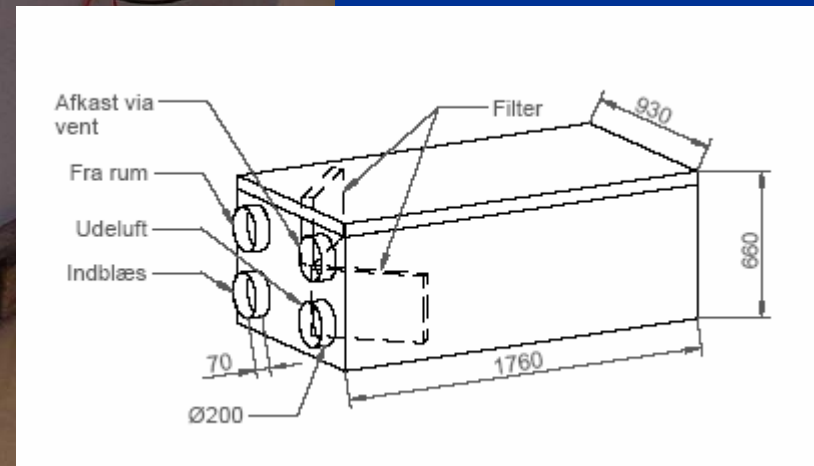

# The ventilation system in the low-energy house

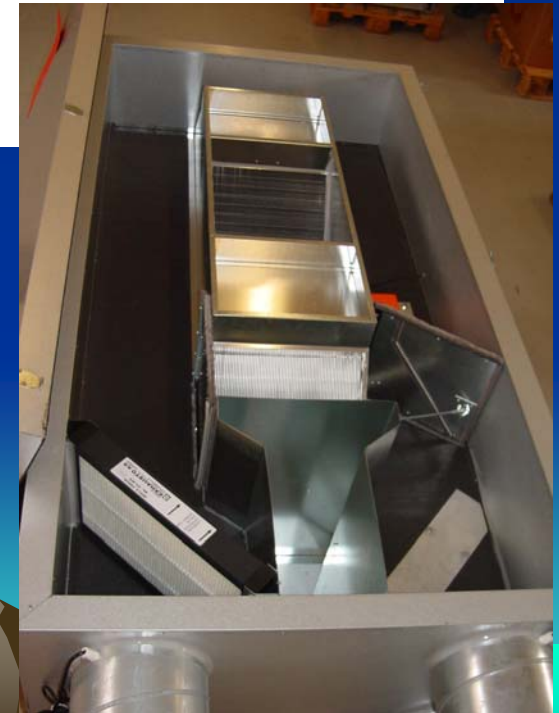
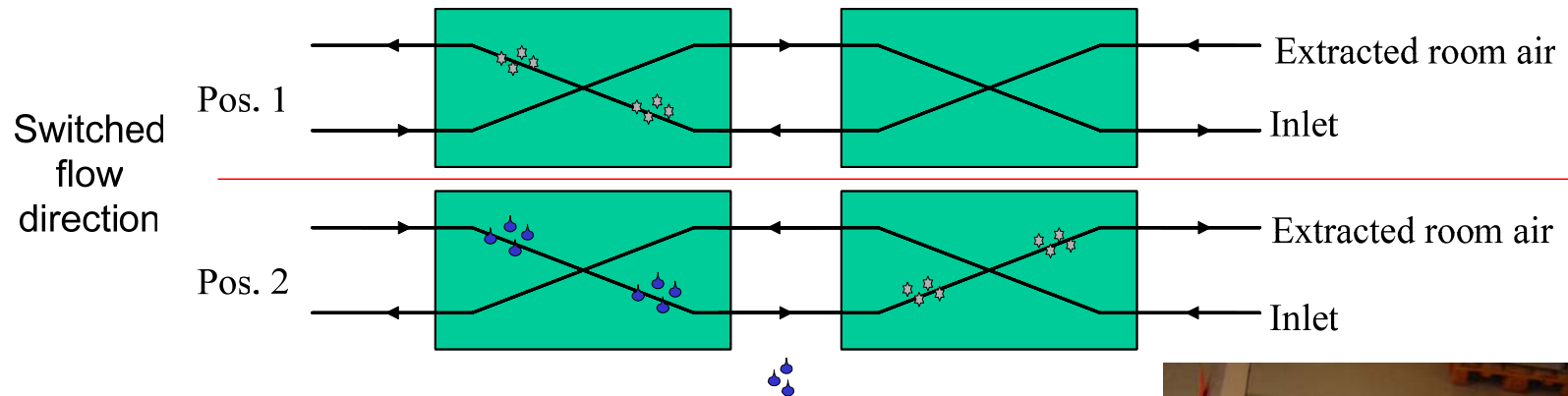

# Laboratory test at DTU

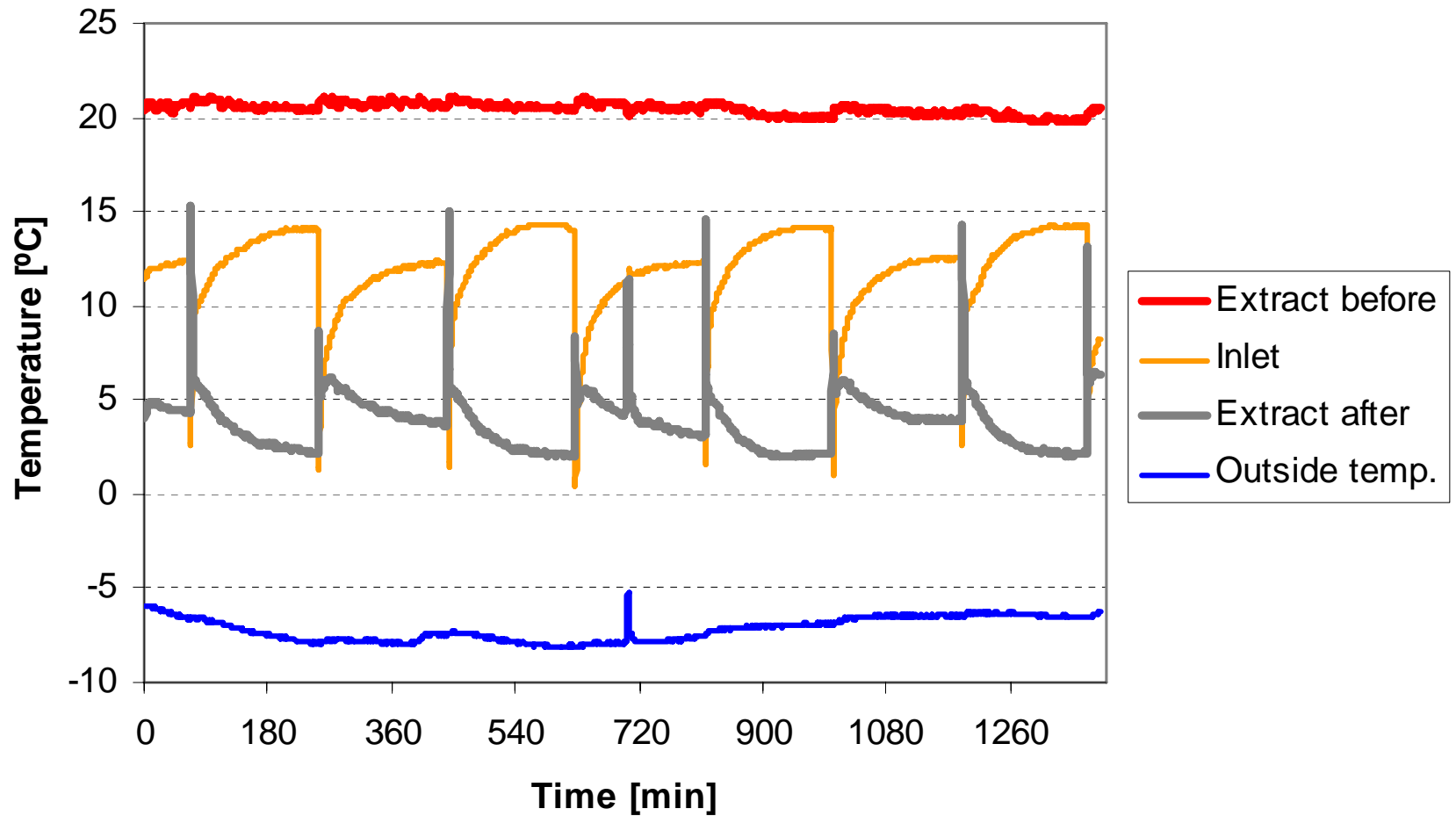

# Laboratory test at DTU

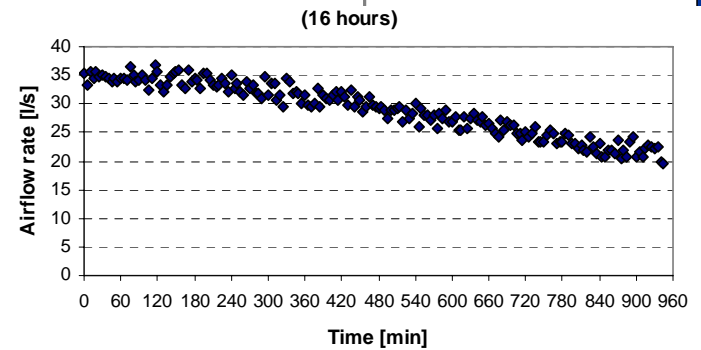
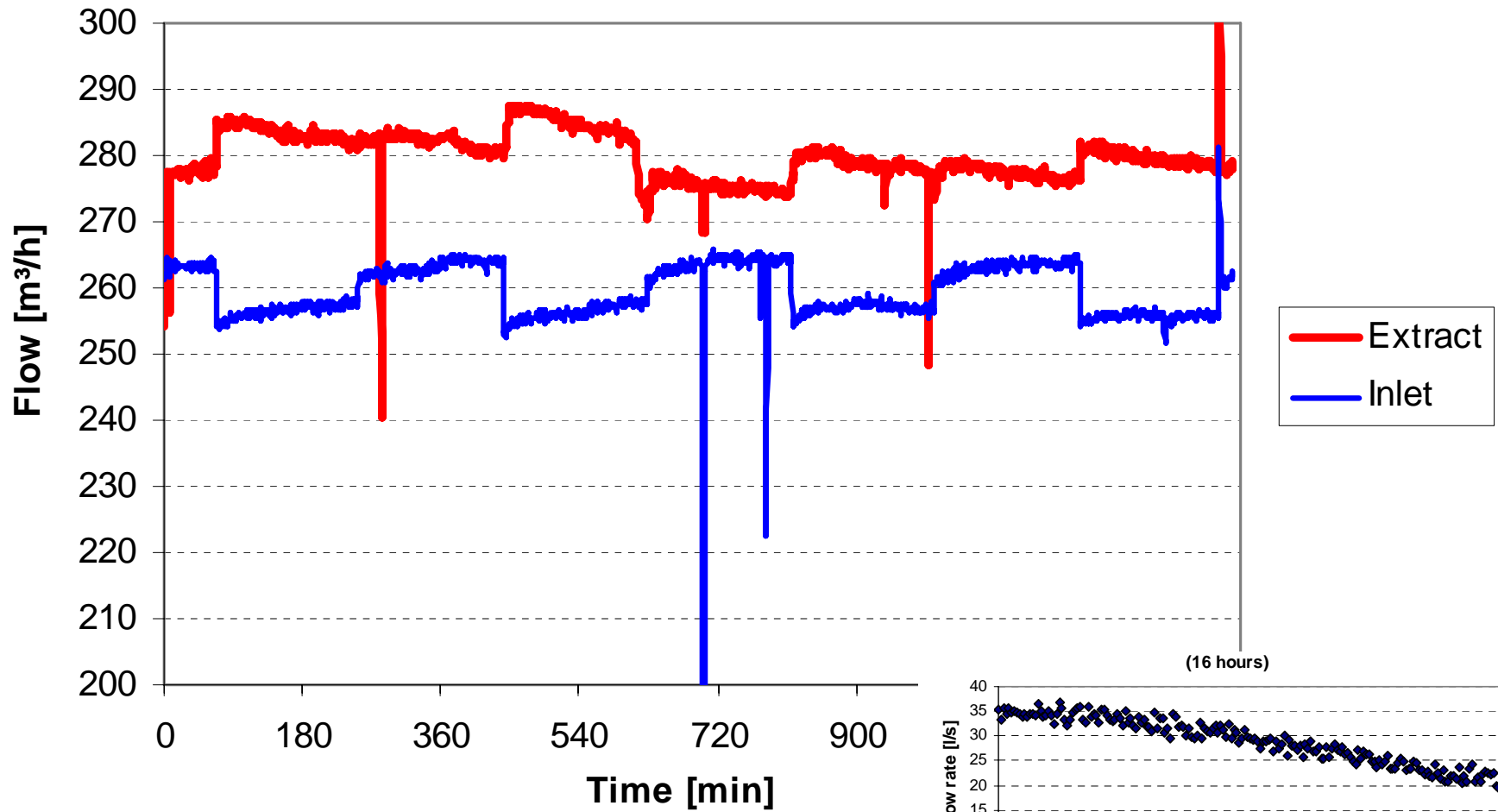

# Laboratory test at DTU

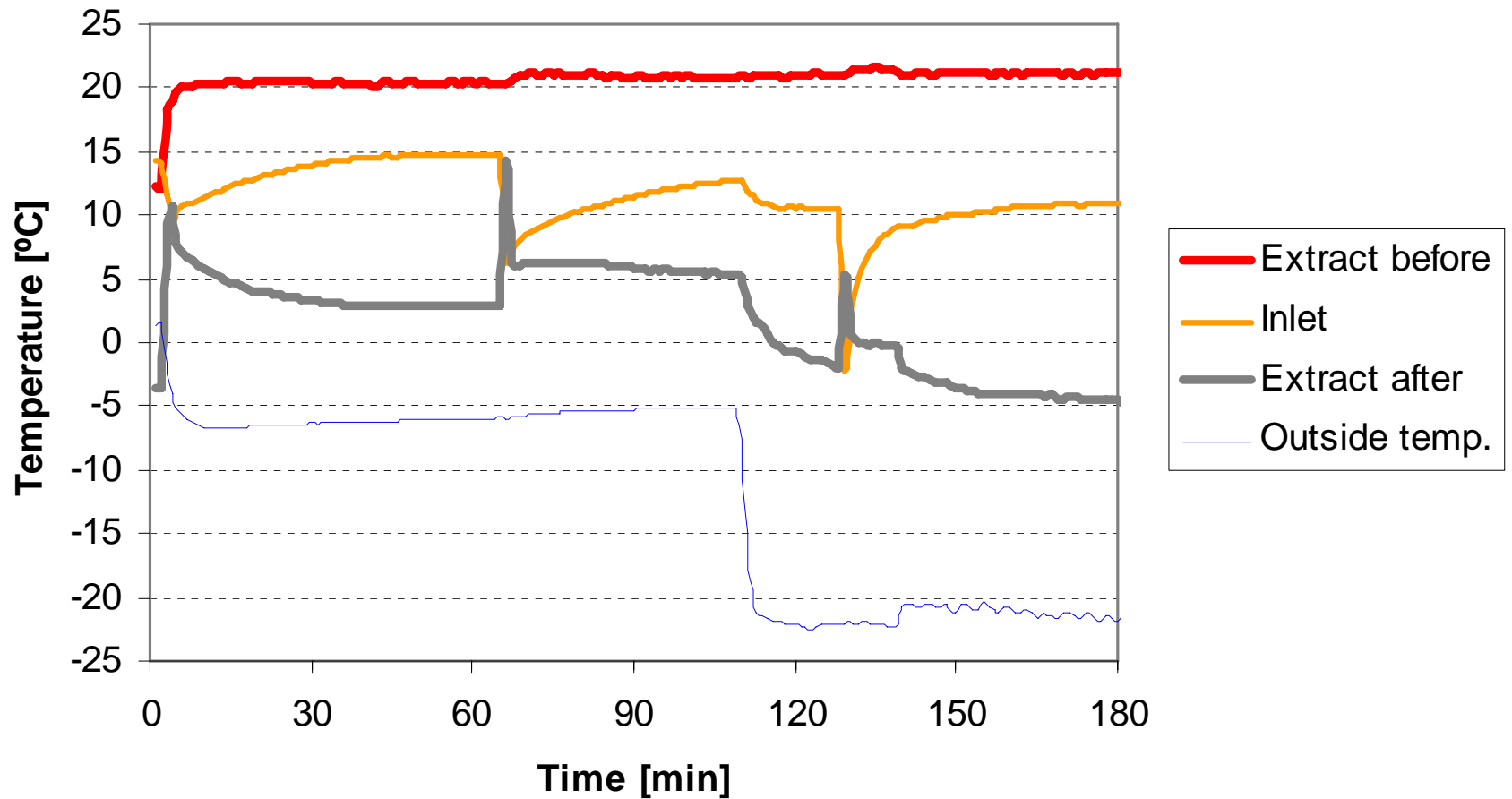

# Other solutions of the frost protection

- Munter's sledge solution
- Serial connection of two exchangers
- Alternating flow in two parallel coupled heat exchangers



# Other solutions of the frost protection

## **Munter's sledge solution**

A small section of the exchanger is inactive due to a plate continuously moving across the inlet airside blocking a small part of the opening to the exchanger.

In this way the exchanger has time to defrost the inactive section.



# Other solutions of the frost protection

## **Serial connection of two exchangers**

Two exchangers coupled in serial connection. When freezing occurs in one of the exchangers, the order of the exchangers is switched around. The frozen exchanger will start defrosting.



# Serial connection of two exchangers

## Case 1

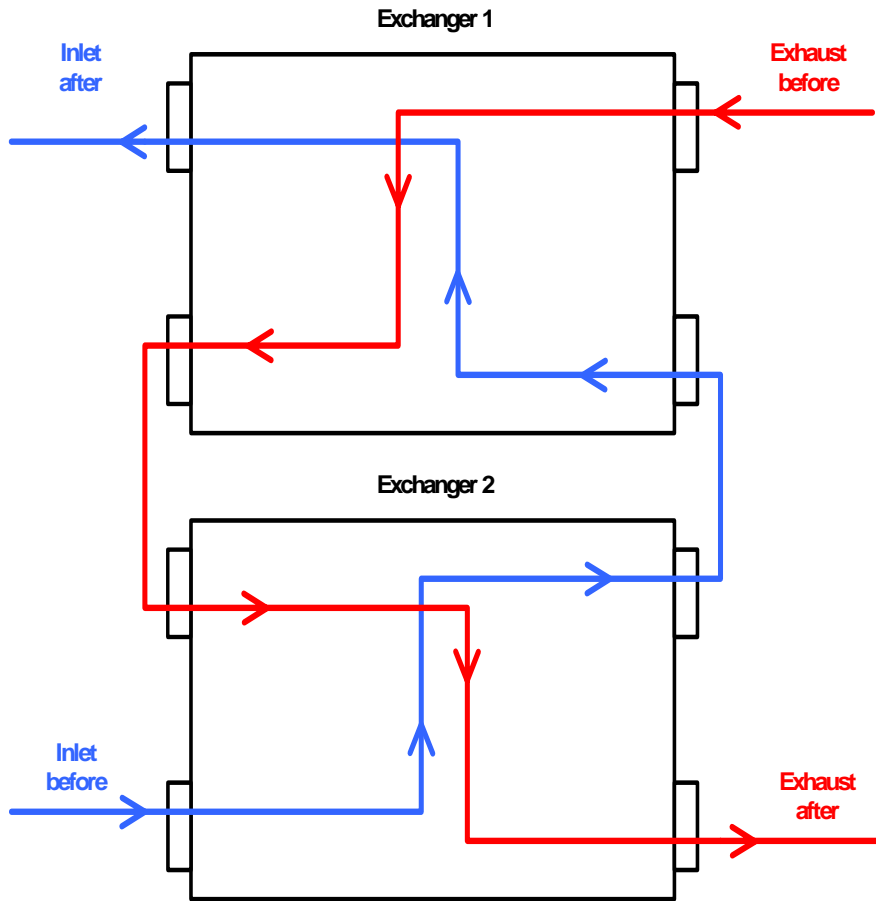

## Case 2

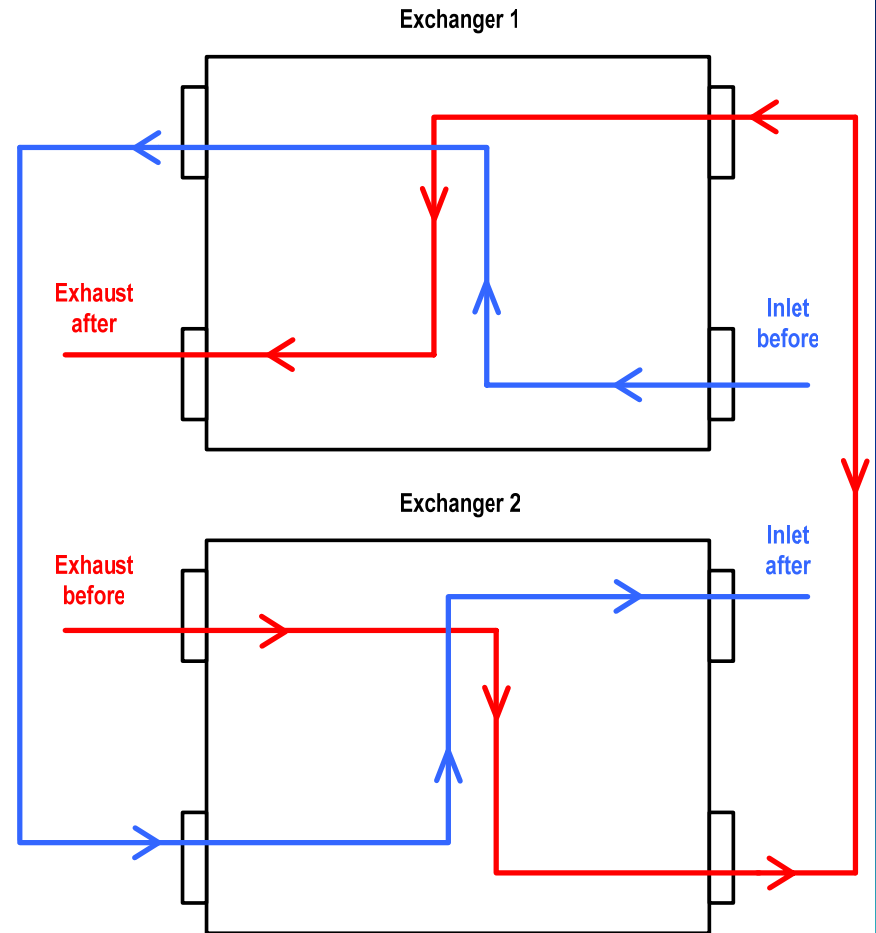

# Alternating flow in two parallel coupled heat exchangers

A large counter flow box exchanger made of polycarbonate plate. Since condensing water cannot be avoided, the exchanger has to be designed in a way that allows for easy removal of the water without extra pumps or valves.

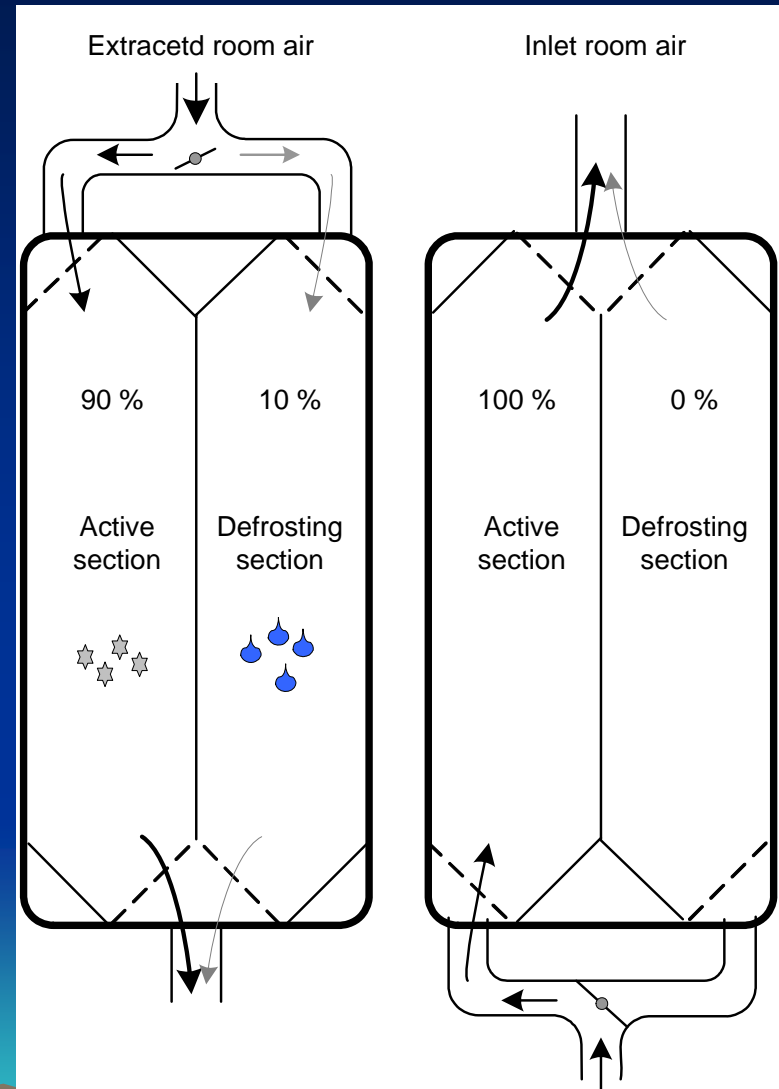

# Other solutions of the frost protection

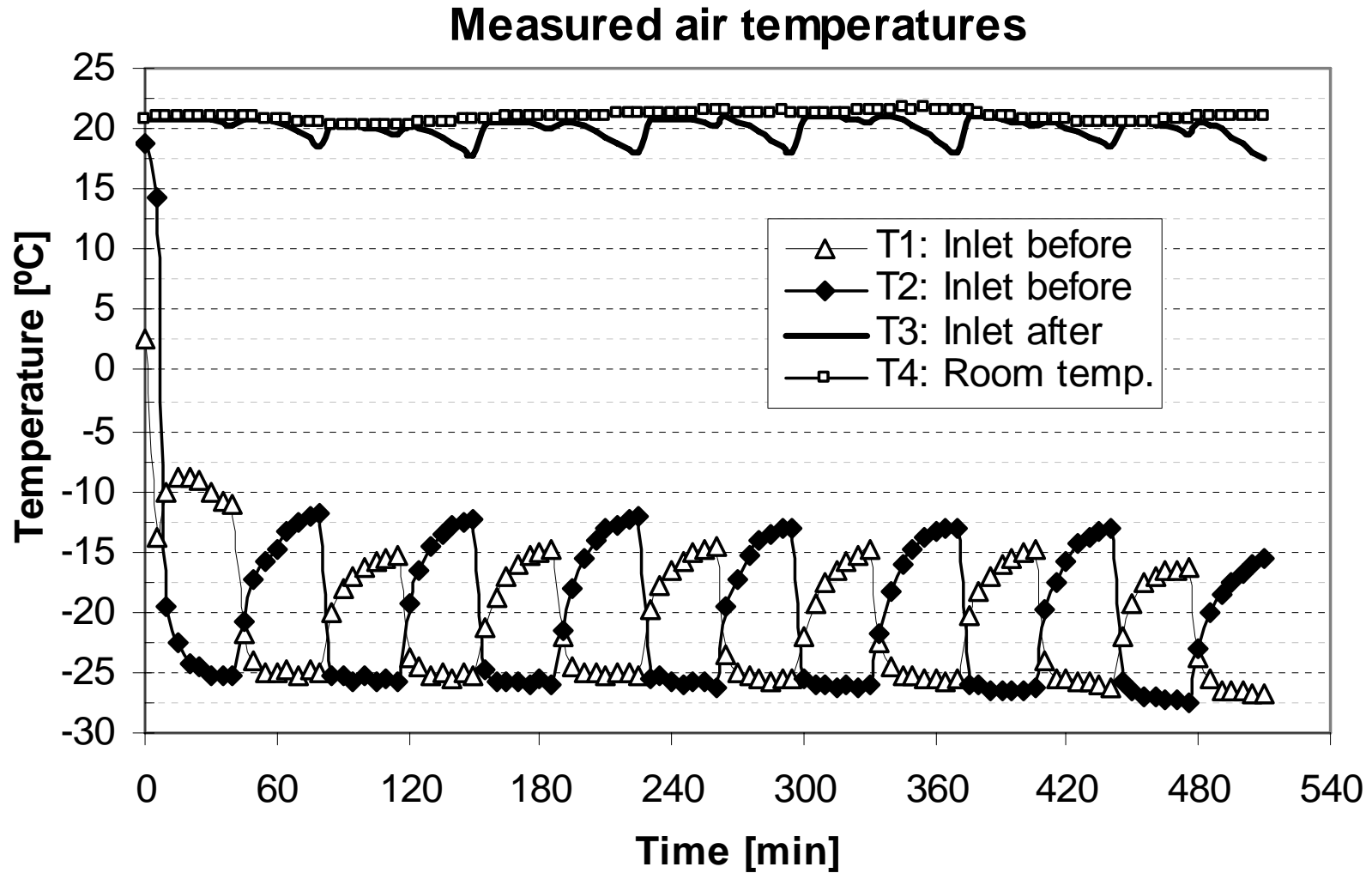

# Test of the alternating heat recovery unit

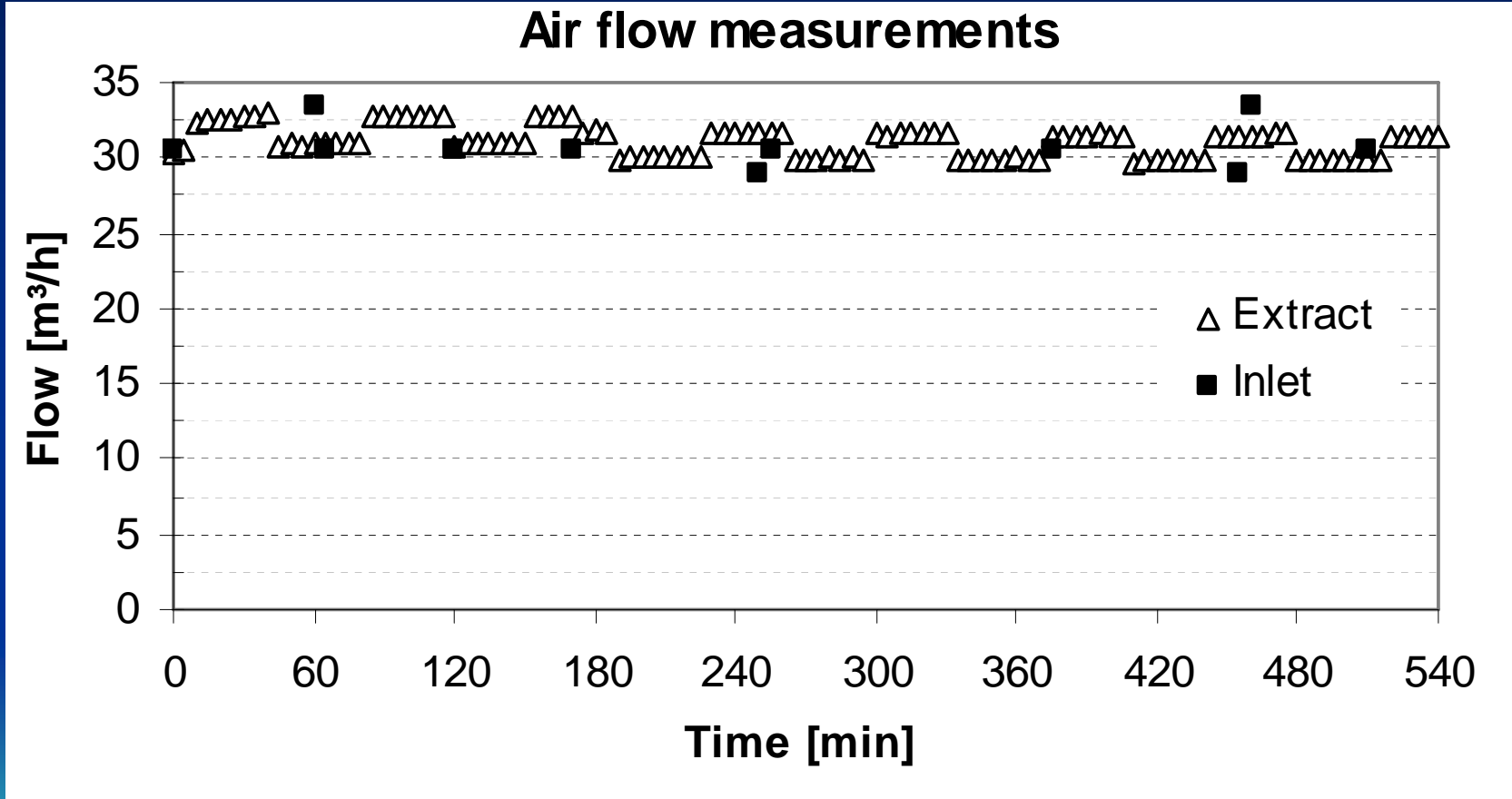

# Conclusion

In cold climates the potential of reducing the ventilation heat loss is huge.

A standard heat recovery unit is not suitable for the cold arctic climate where the low outside temperature easily causes ice formation in the heat exchanger.

A new heat recovery unit was designed and developed for the low-energy house in Sisimiut in cooperation between EXHAUSTO A/S and the Technical University of Denmark. The developed heat recovery unit is capable of continuously defrosting itself.

The defrosting system was tested under laboratory facilities showing that the system worked as intended but still there was a need for extra after heating to minimize the risk of draft for the occupants

# Extracted air temperature as function of the heat exchangers efficiency

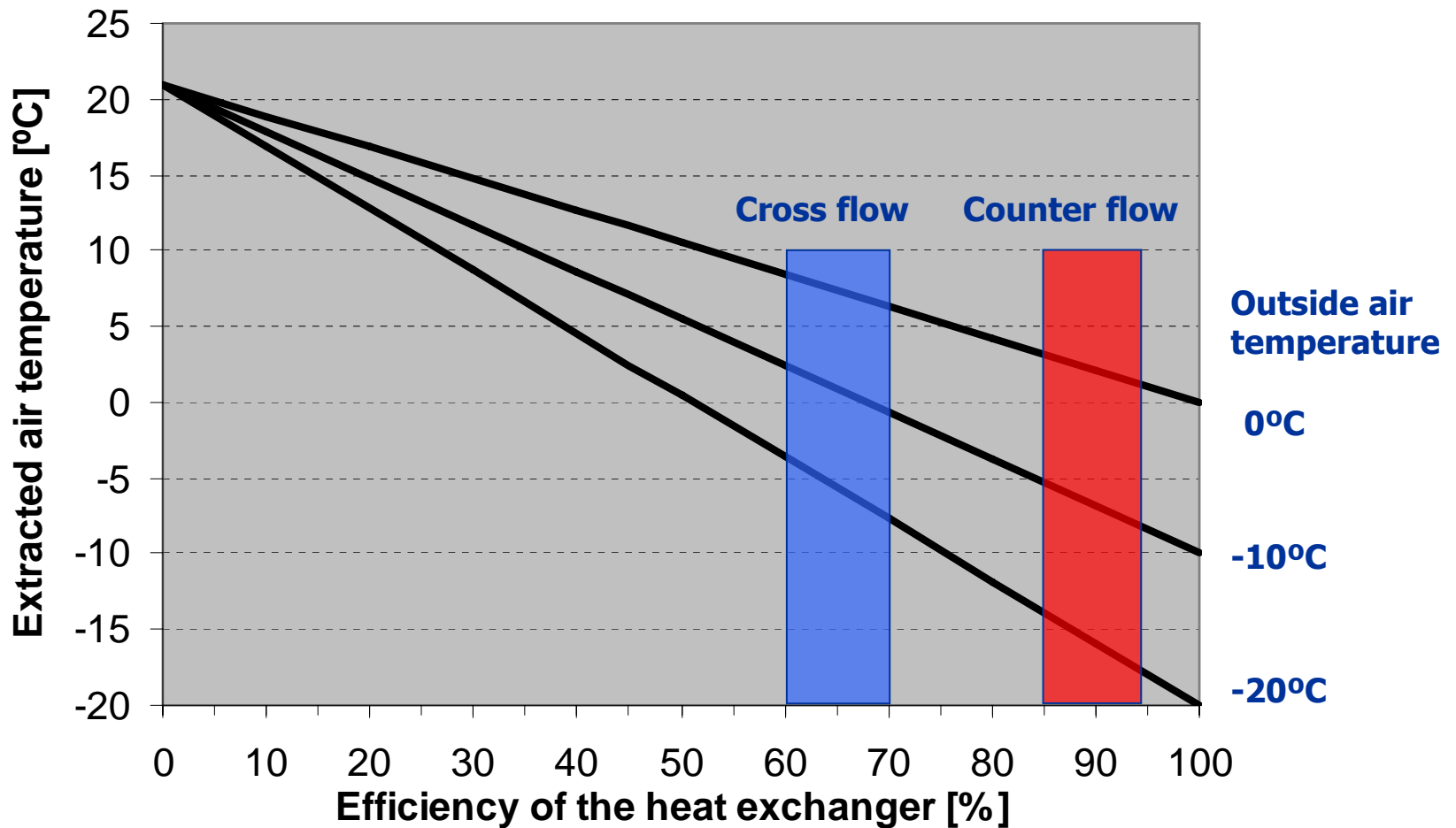

# Test of Serial connection of two exchangers

